

OLTC Dynamic Testing

By

Raka Levi
&
Budo Milovic

OLTC Dynamic Testing

Raka Levi
Montajes e Ingeniería ARCE, S.L SPAIN

Budo Milovic
IBEKO Power AB, SWEDEN

Abstract

This paper presents the concept and means of off-line analysis of the power transformer On Load Tap Changer (OLTC) operating condition, along with interesting findings. Tap Changer failures represent over 40 % of total failures of power transformers. Increasing interest in the methods of analysis presented in this paper stem from their off-line, on-site use, ease of performance and impressive powers of diagnosis. Detected problems discussed are: burned/coked contacts, bouncing contacts, switchover selector problems, and diverter switch opening of the circuit, and more. Results of analysis are illustrated using several troubled power transformers as examples. DV-Win PC software together with a sophisticated new Winding Resistance Ohmmeter and Tap Changer Analyzer were used for field measurement and drawing of the graphs included in this paper.

Introduction

Power transformers are critical, capital-intensive assets for utilities and industry. Transformers are extremely reliable devices. However, many of the transformers in use today have already exceeded their design life. Today transformers are not automatically replaced when they reach their original life expectancy. Rather, they are typically left in service as long as possible. Unlike past years, today power transformers are operated at or above rated power.

Failures appear on all transformer parts with a certain frequency. See Figure 1. International statistical analysis provides data on a sample of 47,000 transformer-years. Failures are organized by the part that is believed to have started the failure.¹ Tap changer failures represent more than 40 % of all failures on power transformers. This is not a big surprise since it is the only moving part under tension. Maintenance interval is in tens of thousands of operations for OLTC, but the Hydro Quebec (HQ) study referenced by Allard² showed 12% require maintenance before the date suggested by equipment manufacturers. Furthermore, P. Kang et al.³ show that about 33% of OLTC failures are caused by incorrect maintenance and bad reassembly. Applying proper diagnostics to avoid these problems will increase transformer reliability by preventing failures, and improve operator safety and environmental conditions.

OLTCs consist mostly of two parts: the diverter switch, which diverts the current during transition (tap change) and minimizes arcing, and a tap selector that selects the taped winding connection. Switchover selectors or inverter switches are included in some designs. Figure 2 shows a schematic of a typical diverter OLTC transition from tap to tap.

Many times, a problem with an OLTC is associated with the selector switch or the diverter. Knowing exactly where a problem lies makes the repair process much simpler. Diverter switches are easy to remove, as they are usually in a separate oil compartment. Selector switch repair may require lowering of the oil in the main tank.

In 1926, Dr. Jansen patented the OLTC principle. The simplest way to describe OLTC operation is that it is a fast make-before-break switch. This means that during the transition from one tap to the other it makes contact with the next position before disconnecting from the previous. During the short period when both are connected, current circulates through the OLTC.

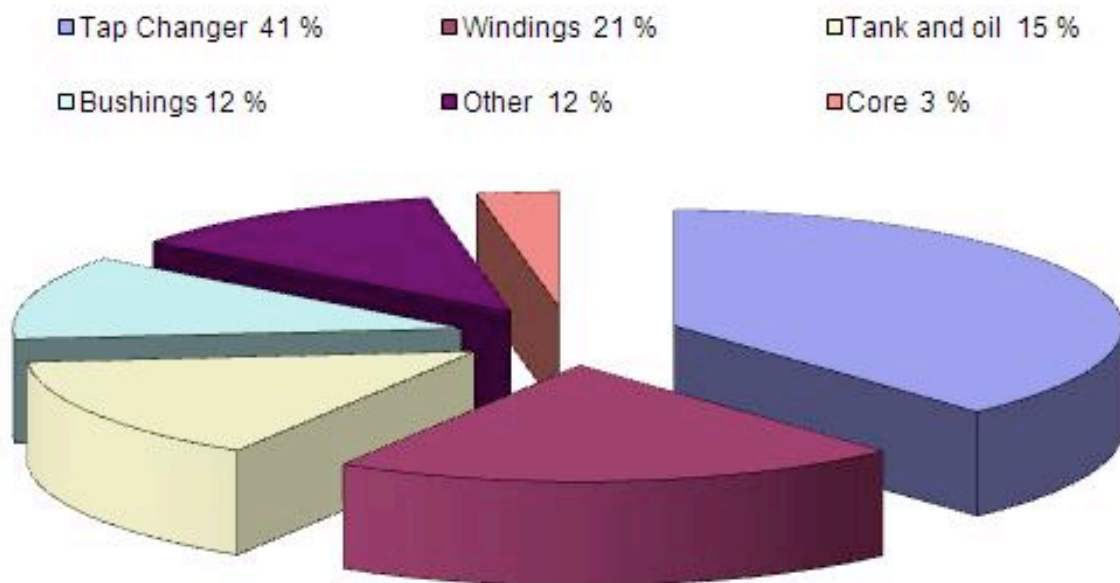

Figure 1
Allocation of Failures for Power Transformers with the OLTC

There are two types of OLTCs, each based on a different method of minimizing circulating current during transition. The fast resistive type uses resistors to minimize the current. See Figure 2. The inductive type uses a preventive autotransformer to minimize the current and at the same time allow operation at mid-position. For larger transformers in the USA, resistive OLTCs are commonly in the primary HV neutral end; smaller transformers (100MVA and below) commonly use inductive type OLTCs in secondary winding.

The advantage of any test method is to be simple and obvious; Dynamic Resistance Measurement (DRM) does exactly this. DRM provides a graph that clearly shows where problems are detected. Zooming into the graph one can easily visualize and diagnose bad selector contacts. Figure 3 compares before- and after-repair graphs.

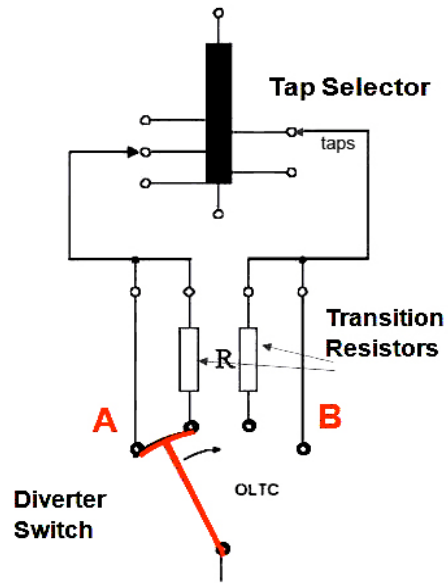

Figure 2
Selector Diverter OLTC Resistive Scheme

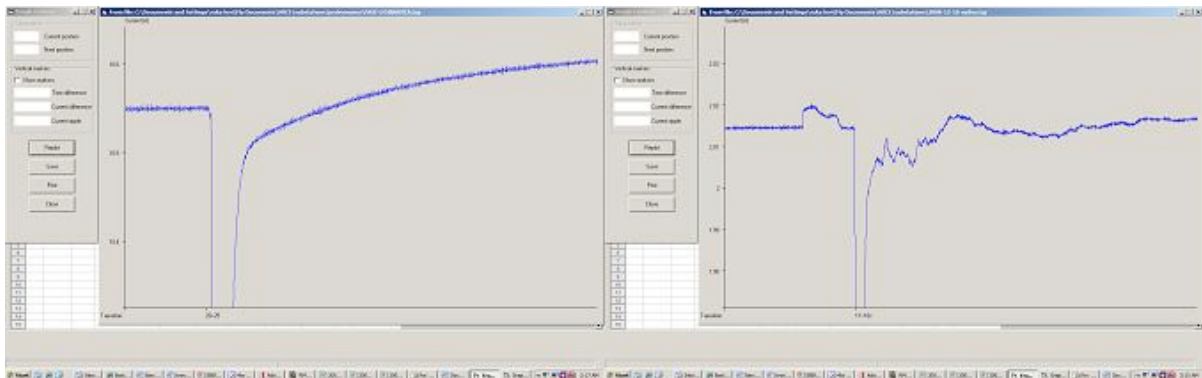

Figure 3
DRM Graphs Showing Good Contacts (left) and Badly Burned Contacts (right). In this strip chart recording, current in the vertical axis is plotted against time in the horizontal axis.

The photograph in Figure 4 shows damaged tap selector contacts of a power transformer's OLTC.

TRANSFORMER DYNAMIC RESISTANCE MEASUREMENT

Until very recently, power transformer maintenance and diagnostics were focused only on the static behavior of contact resistances. In 1994-1995, Verhaart^{4,5} proposed a new DRM method. Its first practical application was reported in 2000⁶.

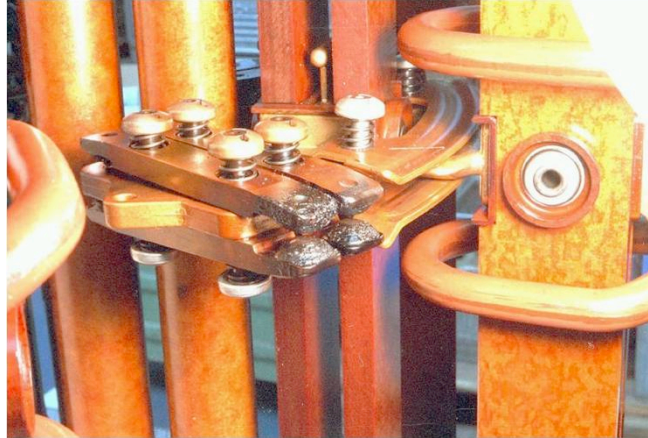

Figure 4
Damaged Tap Selector Contacts

DRM actually measures current change and makes a fast computer recording of data that illustrates current variance over time, as the OLTC transitions from one tap to the other. Data is sampled at a 0.1 msec rate, similar to an oscillograph. The DV-Power RMO60TC instrument supplies 20A dc current as it records with DV-Win software, during transition. The recorded waveforms of current are the inverse of measured resistance, i.e., the higher the resistance the lower the current. The scheme of the measurement method for the dynamic resistance is shown in Figure 5.

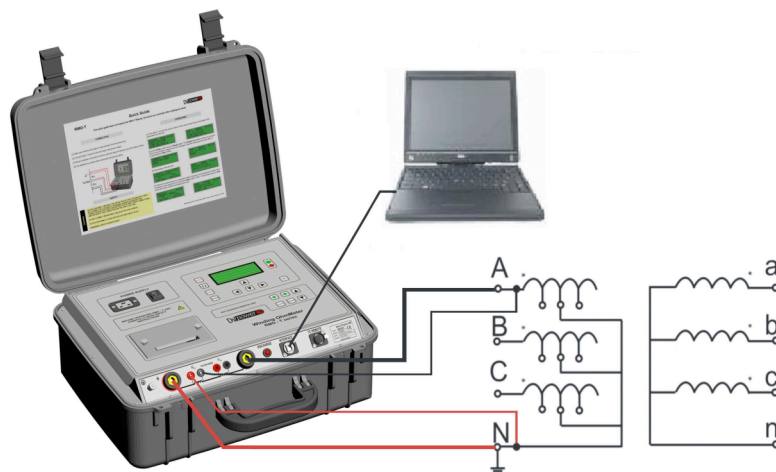

Figure 5
Method for the OLTC Analysis of Power Transformers

Switching problems of the diverter switch can be found by analyzing several key features of the dynamic resistance graph. See the simple diverter transition graph in Figure 6.

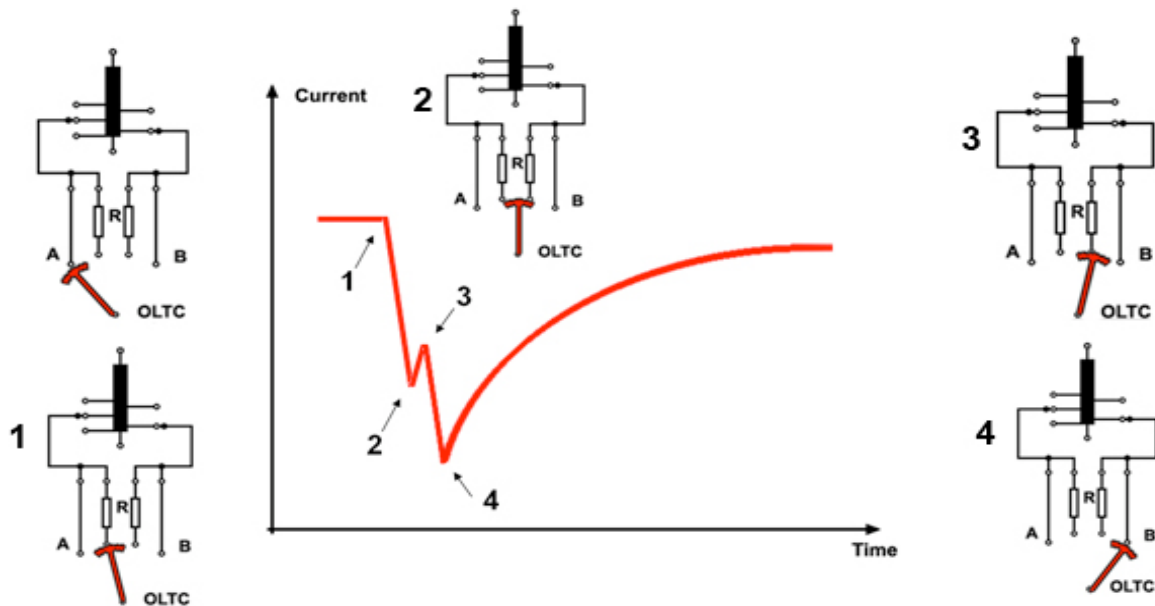

Figure 6
Dynamic Behavior of the Diverter Switch

While testing the OLTC, the instrument continuously records current as positions of the OLTC are changed. The measurement is performed very fast without necessity to discharge the transformer and charge it again for all tap positions.

If an opened circuit in the tap changer is detected, the message “Discontinuity” is clearly displayed on screen. If the circuit is opened, which is a significant defect, the measuring instrument stops the test.

Figure 7 shows aged OLTC diverter switch contacts, courtesy of Kruger⁷.

Dynamic Resistance Measurement Graph Analysis

Specialized PC software named DV-Win⁸ is used for high speed data acquisition and storing results of transformer static and dynamic resistance measurements. The software operates on a standard PC configuration running the Windows operating system. A USB cable connects the test instrument with the PC. Software controls the test instrument during measurement, downloads, and stores measured results in internal instrument memory.



Figure 7
Aged Diverter Switch Contacts

Results acquired during the change of OLTC positions are saved in a special format that enables graphing of current values while changing from one position to another. Analyzing this graph, it is possible to diagnose the operating condition of OLTC switching elements. After each position change, the software displays a graph showing current value change during the transition between two subsequent positions.

Of course, certain expertise is required for accurate diagnostics. Our experience has shown that there is a great variety of tap winding designs, diverter switch and arcing tap switch constructions. All this influences the way tests should be performed and data should be analyzed. Figure 8 shows different graph patterns of two typical regulating winding designs: fine/coarse regulation, and addition/subtraction one.

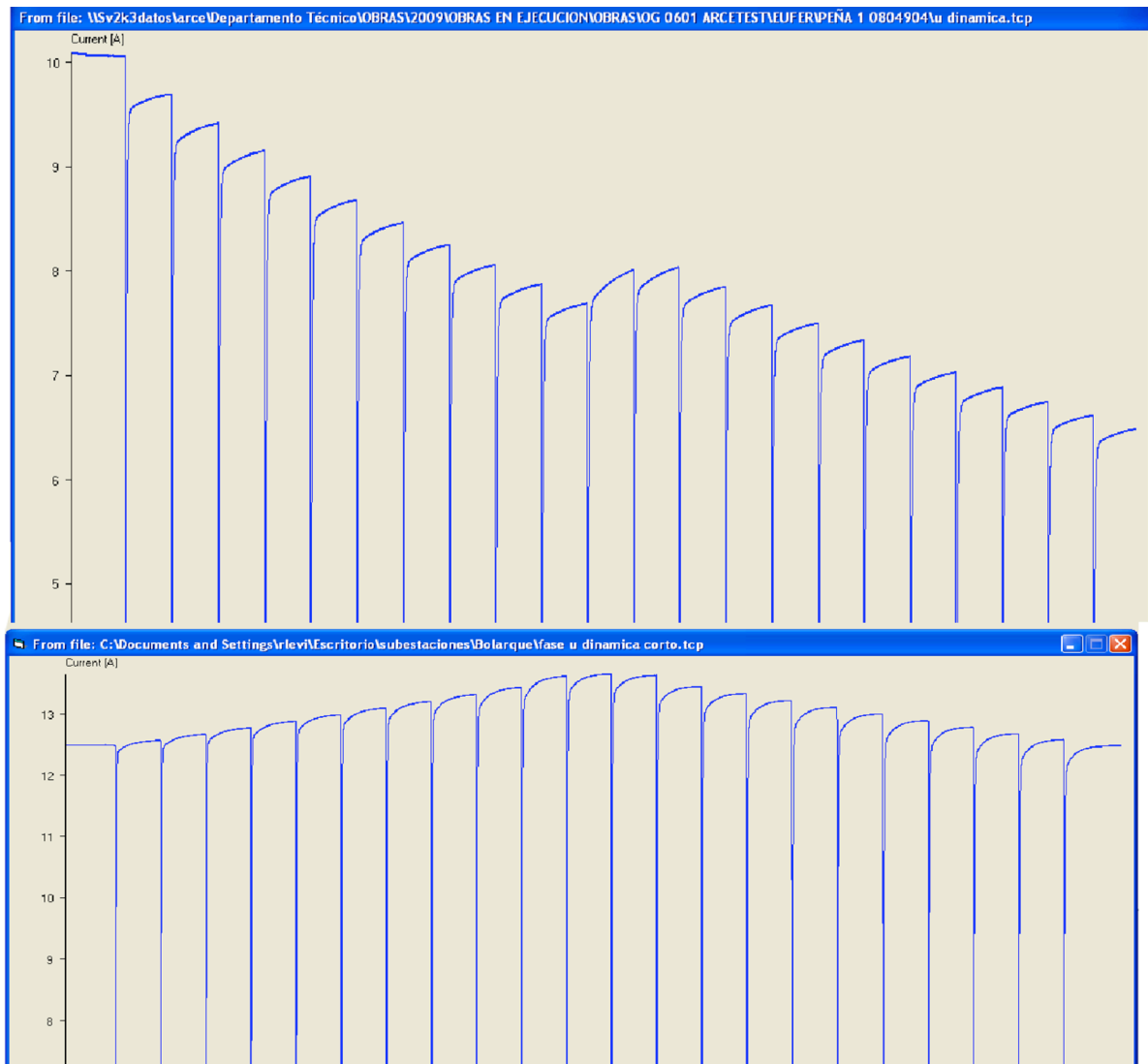

Figure 8
Fine/coarse Regulation (above) and Adding/subtracting (below)

Figures 8, 9, 10, 11 and 12 show current in the vertical axis plotted against time in the horizontal axis. Many OLTC designs go through two positions without stopping around the neutral position. As this type of OLTC functions a diverter switch operates, changeover selector changes configuration, and selector switch changes the tap⁹. Figure 9 shows a detected problem that could be attributed to the position 10 to 11a change; however, the anomaly in the graph is at beginning of the change from 11a to 11 that is, in this case, a neutral position.

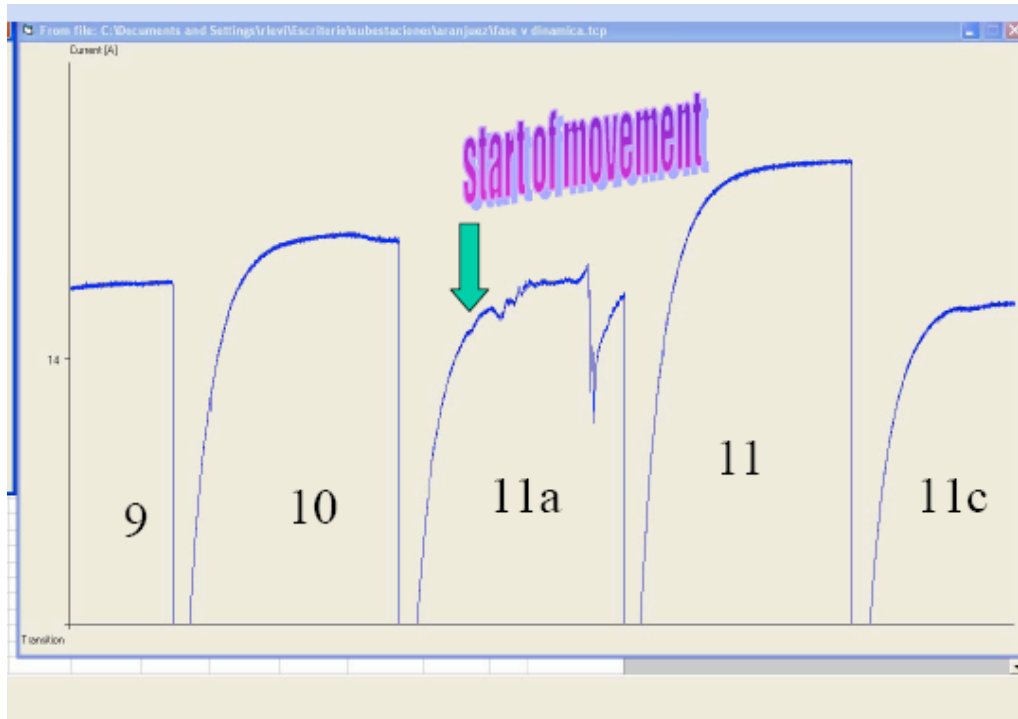

Figure 9
Change-over Selector Switch Problem

Figures 10 and 11 show current values measured while the OLTC positions were changed from minimum to maximum on two different transformers: T1 and T2. Values on abscissa denote recording time; each vertical line is one transition. Values on the Y axis denote current value during the transition.

Figure 10 shows a graph of the bad operating condition of T1's OLTC. A rolling arcing tap switch moving over a stationary contact caused this problem; wear shows as roughness of the curve. Looking at Figure 10, notice the small vertical drops between large vertical drops; these smaller drops indicate the moment the switch starts rolling.

Figure 11 shows a graph of the bad operating condition of T2's OLTC. Note that in this case T2's OLTC was equipped with a diverter switch. Here the selector switch contacts are worn and this resistance introduces an obvious difference in the current value for each step.

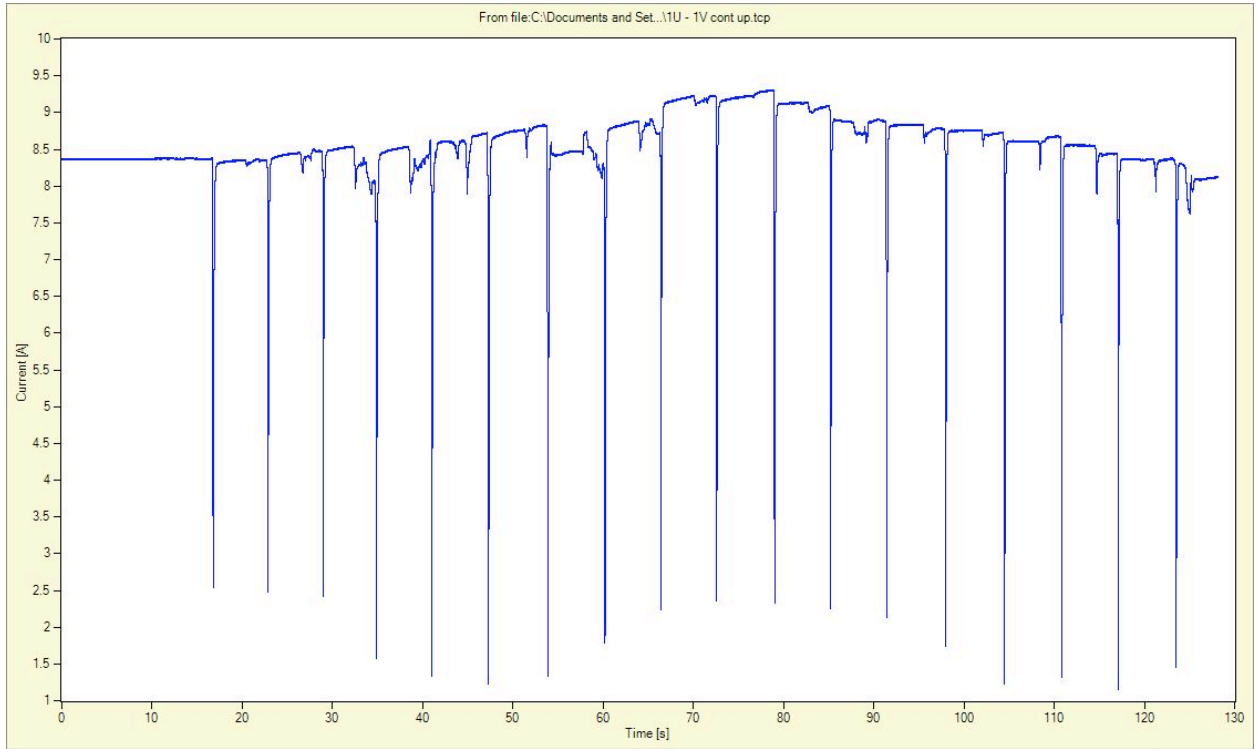

Figure 10
Current Value During Transitions on T1

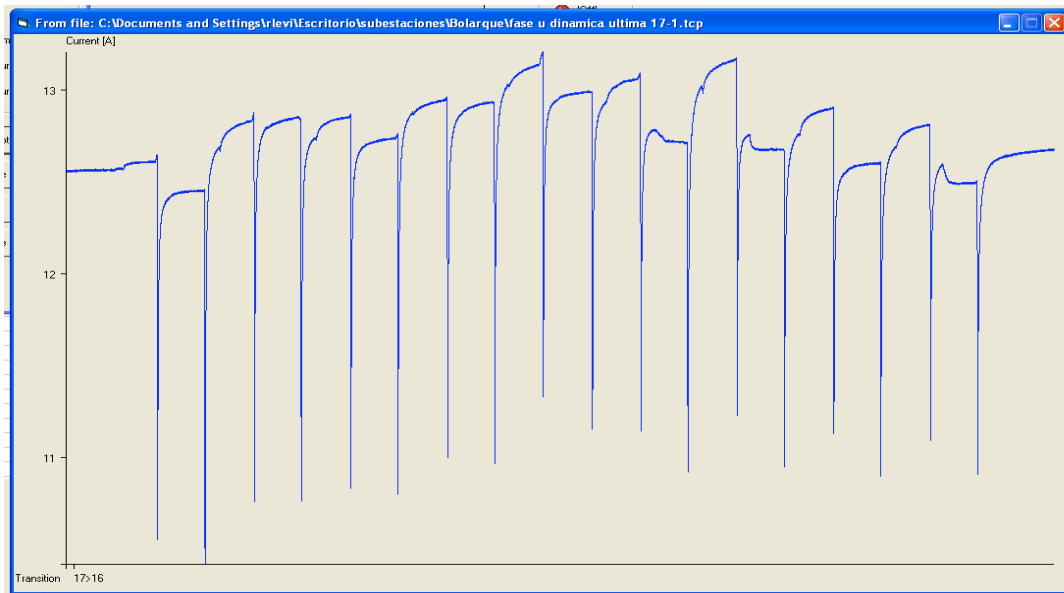

Figure 11
Current Value During Transitions on T2

It is possible to analyze a more detailed diagram by zooming into the interesting parts of the graph. The most interesting part of each transition is the one that shows current value during fast diverter switch operation, the change from one tap position to the next. Typical current value diagram is shown in Figure 12. This particular diagram shows an OLTC that is in good condition.

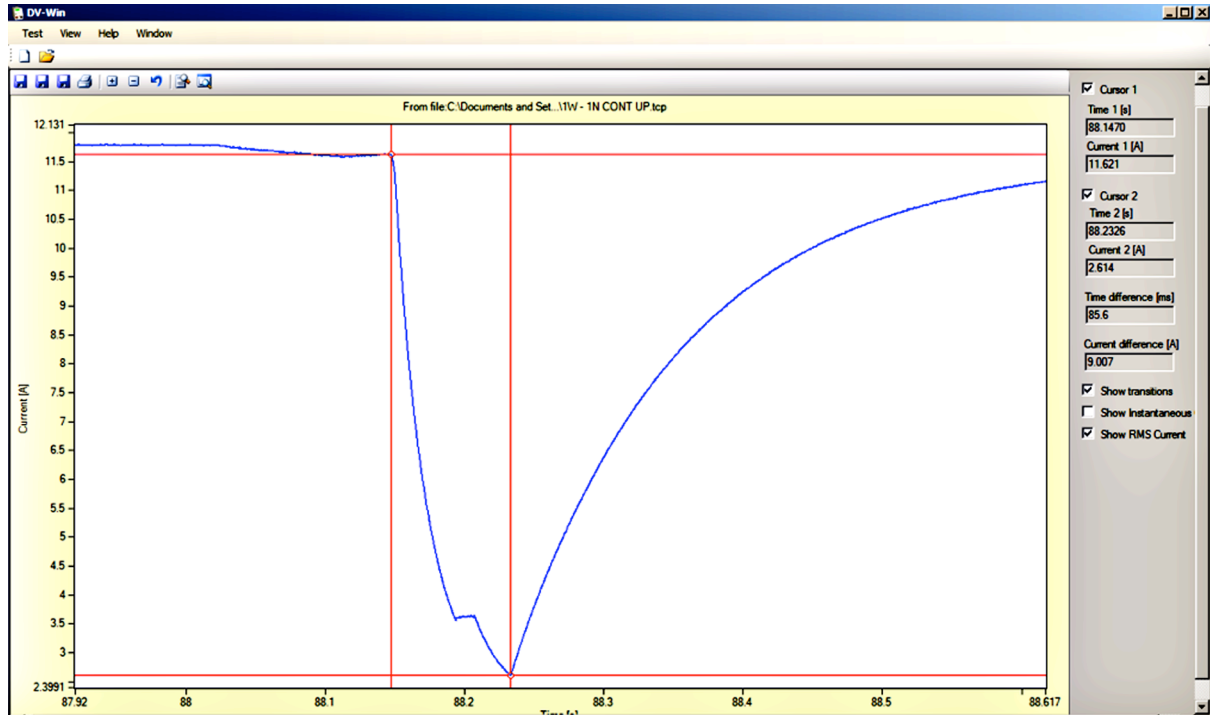

Figure 12
On-screen Markers (in red) Are Used to Measure Time and Amplitude Values of the Current Change During This Good Transition

A separate control window on the screen provides useful tools, such as markers that can be positioned at precise locations on a graph to measure characteristic values of time and amplitude. The values shown on the control window are the time interval between two markers, and current difference between the markers.

In addition to graphical presentation, tabular numeric measurements provide for quick comparison of ripple, transition time and other parameters used for diagnostics at each tap position. See Table 1.

Table 1
 Numeric Presentation of Measured Parameters at 16 Tap Positions

Date and Time	Connection	Current [A]	R1(25°C) [mOhm]	R1(75°C) [mOhm]	V1 [mV]	Ripple %	Tap Position	Transition Time [ms]
5/8/2010 13:58	1U - 1V	10.74	291.2437	347.36	3126.641	0	1	0
5/8/2010 13:59	1U - 1V	10.93	285.0616	339.9868	3116.955	8.5	2	46.8
5/8/2010 14:00	1U - 1V	11.15	279.0591	332.8277	3112.185	8.5	3	48.1
5/8/2010 14:00	1U - 1V	11.37	272.5099	325.0166	3097.266	8.4	4	46.8
5/8/2010 14:01	1U - 1V	11.57	266.7406	318.1357	3085.091	8.4	5	45.5
5/8/2010 14:02	1U - 1V	11.78	260.5021	310.6952	3067.431	8.8	6	45.7
5/8/2010 14:02	1U - 1V	11.99	254.1737	303.1474	3046.654	9.5	7	44.4
5/8/2010 14:03	1U - 1V	12.25	246.5858	294.0975	3019.804	10.4	8b	50.6
5/8/2010 14:04	1U - 1V	12.25	245.8175	293.1812	3010.838	11.2	9	48.5
5/8/2010 14:04	1U - 1V	12.52	239.5066	285.6543	2997.603	11	10	50.8
5/8/2010 14:05	1U - 1V	12.74	233.2372	278.1769	2972.571	10.9	11	48.8
5/8/2010 14:05	1U - 1V	13	227.2802	271.0721	2954.72	10.9	12	47
5/8/2010 14:06	1U - 1V	13.24	221.025	263.6117	2926.333	10.6	13	45
5/8/2010 14:07	1U - 1V	13.52	214.9339	256.347	2906.878	11.2	14	45.6
5/8/2010 14:07	1U - 1V	13.77	208.6241	248.8214	2873.16	12.2	15	45.7
5/8/2010 14:08	1U - 1V	14.16	200.9709	239.6936	2845.206	13.2	16	50.9

As a problem example¹⁰, Figure 13 shows current value during the transition with a discontinuity; the diverter switch did not make before breaking with the previous position. This current diagram is related to an unacceptable operating condition of OLTC diverter elements. The program automatically stopped the test when discontinuity was detected. Dissolved Gas Analysis (DGA) shows that any opening (breaking before making) creates a high level of combustible gasses, especially acetylene. See Table 2.

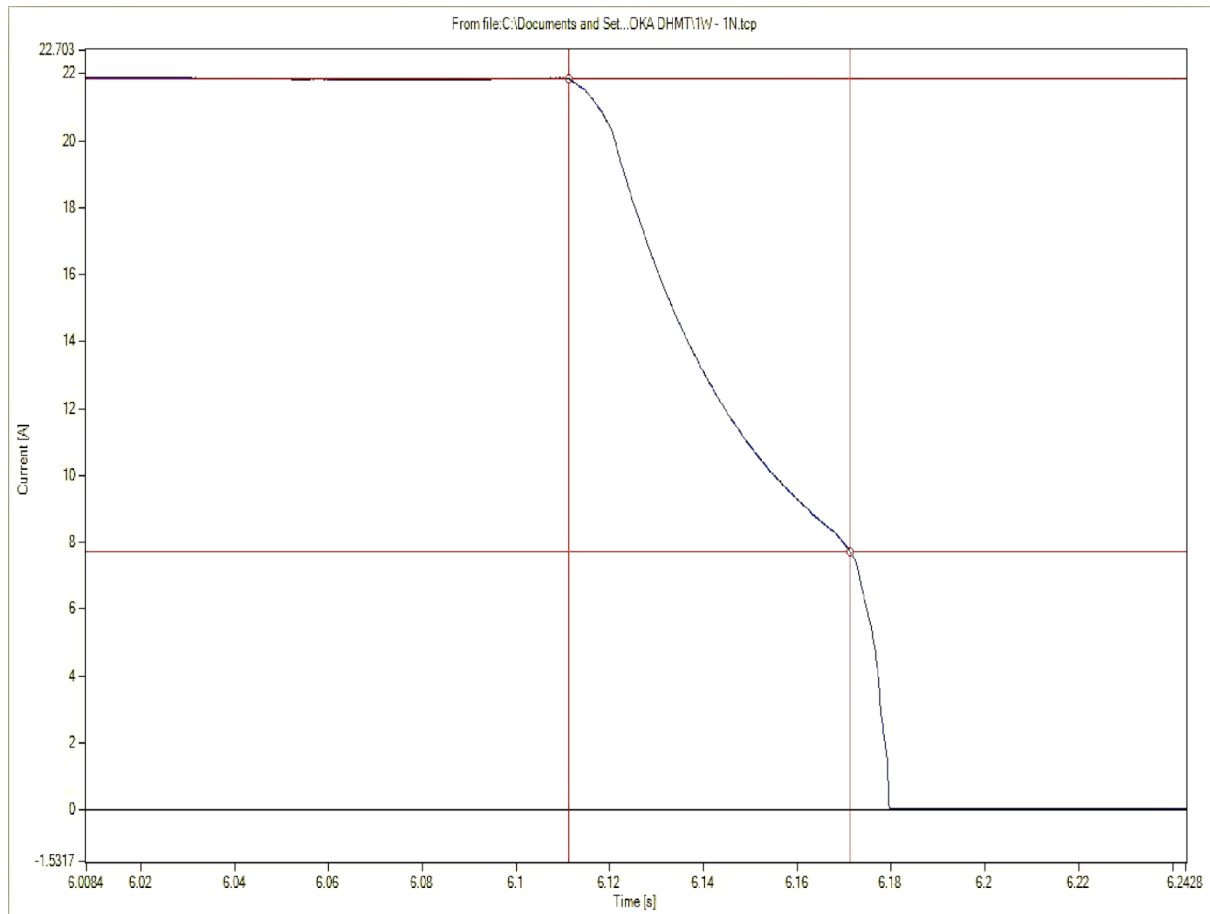

Figure 13
Current Interruption During Bad - Interrupting Transition

The troublesome power transformer, that was the source of the graphic discontinuity example in Figure 13, cleared on Bucholz relay a couple of times before DRM tests indicated opening during the W phase OLTC transition. Once the problem was identified, the diverter was removed and repaired on site.

Table 2
DGA of Buchholz Relay (all values are in ppm)

H ₂	O ₂	N ₂	CH ₄	CO	CO ₂	C ₂ H ₄	C ₂ H ₆	C ₂ H ₂
414444	35302	349751	108117	15891	19063	10958	278	2915

Since this is a dc test, it leaves the magnetic core magnetized. In addition, cores of the current transformers on associated bushings may also be magnetized. This magnetization may cause problems, such as high inrush and asymmetry, which may in turn cause inadvertent relay operation. Also, other diagnostic test results are influenced by remanent magnetism. Consequently, this test is performed as the last test in the battery of measurements for transformer condition assessment. As an added benefit, an automatic demagnetization process is performed after the test to remove any remanent magnetism in the core.

Conclusion

The winding resistance measurement is a standard test performed every time a transformer is tested. Dynamic Resistance Measurement is a fast-sampling record of the test current in time, while the OLTC changes position. Comparison with “fingerprint“ results, which were taken when the transformer OLTC was in good condition and to adjacent phases, allows for an efficient analysis.

Defective selector contacts could be detected by measuring static resistance in all OLTC positions. Switching problems of a diverter switch could be detected by recording the dynamic resistance. It is recommended to measure starting from the first position to final position and back, and then to compare the measurement results in the same positions.

DRM is a new method that is not widely known around the world. A big advantage of this method is that if there is a problem inside the OLTC, it can often be identified externally, without opening the OLTC, removing oil from the tank, etc. Thus, significantly reducing maintenance and service costs.

A working group composed of experts and practitioners from 10 countries was formed to exchange information and standardize DRM test procedures; this made it possible to compare results and learn from each other. The vast variety of OLTC designs, operating methods, regulating winding configurations, and contact types and materials make analysis very type-specific¹¹. Collecting fingerprints and failure graphs for each type of OLTC would be very helpful. Procedures applied by members of the working group vary – from single phase to three phase testing, from 1A to 20A test current, from step-by-step static and dynamic combined measurement to separate procedures. Standardization of the testing methodologies used in specific applications will help make the comparison of results more widely relevant and applicable. The overriding benefit of this exchange will be in the domain of increased diagnostic power, and detection of problems in OLTCs.

References

1. “*Transformer failure causes in Germany*”, IEH Liebnitz University Hanover -Shering Institute, Institute of Electric Power Systems, Division of High Voltage Engineering.
2. Presentation on OLTC diagnostics, Laurent Allard, ABB Secheron, Euro TechCon Chester, UK, 2010.
3. P.Kang, D. Birthwistle, et al. “*Non invasive on line condition monitoring of OLTC*”, IEEE Proceedings, January 2000, Generation, Transmission and Distribution, Volume 3, pp. 2223-2228.
4. H.F.A.Verhaart, KEMA. “*Tussenrapport over faaloorzaken van distributie- en koppeltransformatoren op basis van de onvoorziene nietbeschikbaarheid.*”, Rapport 43613-T&D 94-102278, 1994.
5. H. F. A. Verhaart, “*A diagnostic to determine the condition of the contacts of the tap changer in a power transformer.*”, CIRED, Brussels, Belgium, 1995, paper 1.13.
6. “*Dynamic resistance measurements in LTC*”, Luis Miguel Perea, Angel Ramos Gómez Unión Fenosa Distribución, Spain, José Luis Lozano Gómez Norcontrol Soluziona, Spain - Proceedings of the EuroDoble Colloquium 2000.
7. Michael Krüger “*Fault location on Power Transformers with electrical measuring methods*” Klaus, Austria, 2007,
8. IBEKO Power AB “*Manual of Winding Resistance Ohmmeter RMO60TC*”, February 2008.
9. MR. OLTC Instruction Manual.
10. “*Experience on Dynamic Contact Resistance Test on Eroded and Worn-Out Tap-Changer Contacts*”, R. Samsudin, Yogendra , A.Berhanuddin, Y. Zaidey, M.Haneef , TNB Research Sdn Bhd Malaysia.
11. “*Reproducibility of Dynamic Resistance Measurement Results of On-Load Tap Changers – Effect of Test Parameters*”, J.J. Erbrink¹, E. Gulski¹, J.J. Smit¹, R. Leich², P.P. Seitz³ and B. Quak³; ¹ Delft University of Technology, Delft, the Netherlands, ² Liandon, Alkmaar, the Netherlands, ³ Seitz Instruments AG, Switzerland – presented in Japan 2010.

Biography

Raka Levi, Dr. Eng., has over 25 years of asset performance and condition assessment experience, specializing in apparatus test, monitoring and diagnostics. Raka started a European technical committee on HV diagnostics and maintenance, and coordinated its activities as the Convener. He has been running committees that assemble asset managers and operation specialists of major European utilities since 1995. He is a Senior Member IEEE. His education includes a Ph.D. in the field of HV diagnostics for circuit breakers, and ME from the RPI, New York.

Budo Milovic is a senior test engineer at IBEKO Power AB, Sweden. Since receiving his Diploma of Engineering degree, he has worked in the field of HV apparatus diagnostics and testing in substations.